

## ME 2580 – Dynamics

### Dependent Motion: Pulley Problems

When two or more masses are connected through a series of pulleys by cables or ropes that *do not stretch*, the positions, velocities and accelerations of the masses are related by purely *kinematical relationships*. These relationships may be found by invoking the “no-stretch” condition of the cable or rope. An example of such a system is shown in the figure.

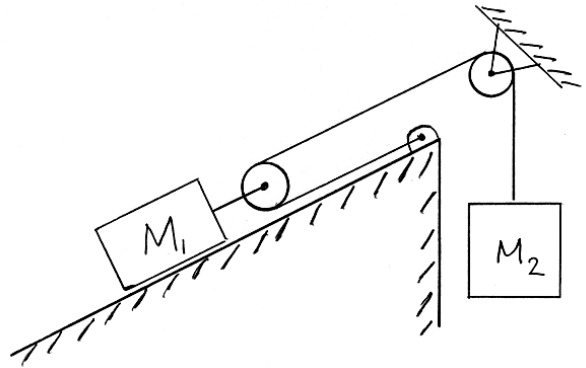

To write the “no-stretch” condition for this system, we first define the *distances*  $s_1$  and  $s_2$  as shown. Note that these distances not only measure lengths of certain portions of the cable, but they also measure the motion of the two masses relative to fixed reference positions. The “no-stretch” condition of the cable can then be written as

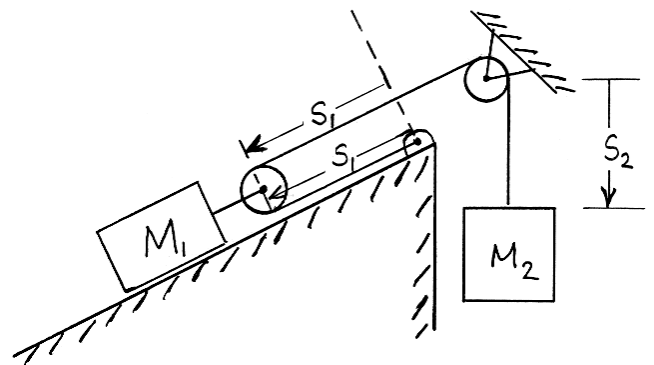

$$2s_1 + s_2 = \text{constant}$$

Note that  $2s_1 + s_2$  *does not represent* the total length of the cable; however, the only lengths that are left unaccounted for are all constant. So, the length  $2s_1 + s_2$  itself must be constant.

The relationship between the velocities and accelerations of the masses are found by *differentiating* the “no-stretch” condition.

$$\begin{aligned} 2\dot{s}_1 + \dot{s}_2 &= 0 & \text{or} & & \dot{s}_2 &= -2\dot{s}_1 \\ 2\ddot{s}_1 + \ddot{s}_2 &= 0 & \text{or} & & \ddot{s}_2 &= -2\ddot{s}_1 \end{aligned}$$

So, if  $M_1$  is moving *down* the plane, then  $M_2$  is moving *upward* at *twice* the rate. This statement applies to both the velocities and accelerations.