

Introductory Control Systems

State-Space Models and Transfer Functions

References:

F.H. Raven, *Automatic Control Engineering*, 5th Ed., McGraw-Hill, Inc., 1995.

R.C. Dorf & R.H. Bishop, *Modern Control Systems*, 11th Ed., Pearson Prentice Hall, Inc., 2008.

K. Ogata, *Modern Control Engineering*, 5th Ed., Pearson Education, Inc., 2010.

As presented in previous notes, dynamic systems can be modeled (or represented) using transfer functions or a set of state-space equations. Transfer functions are used primarily for single-input, single-output systems. State-space equations can be used for multiple-input, multiple-output systems, are very versatile, and can be used to model very complex systems. The following pages describe how to convert a set of linear, state-space equations with constant coefficients to transfer functions and how to convert a transfer function to a set of state-space equations.

Converting State-Space Equations to Transfer Functions

Laplace transforms are used to find transfer functions from state-space equations. Consider the state-space equations with constant coefficient matrices.

$$\dot{\underline{x}} = [A]\underline{x} + [B]u \quad (1)$$

$$\underline{z} = [C]\underline{x} + [D]u \quad (2)$$

Here,

$\underline{x}(t)$ is the $N \times 1$ vector of time-varying states – the elements are called state variables

$u(t)$ is the $M \times 1$ vector of time-varying input signals

$\underline{z}(t)$ is the $K \times 1$ vector of time-varying output signals

$[A]$ is an $N \times N$ constant coefficient matrix, $[B]$ is an $N \times M$ constant coefficient matrix

$[C]$ is a $K \times N$ constant coefficient matrix, $[D]$ is a $K \times M$ constant coefficient matrix

Applying Laplace transforms to Eq. (1) gives

$$s \underline{X}(s) = [A] \underline{X}(s) + [B] U(s) \quad (3)$$

or

$$(s[I] - [A]) X(s) = [B] U(s) \quad (4)$$

Here, $[I]$ is the $N \times N$ identity matrix. Cramer's rule can be applied to Eq. (4) to find the transfer functions from each input $U_j(s)$ to each state variable $X_i(s)$. Each element of the transfer function matrix is itself a transfer function. Using Cramer's rule, it is clear each of the transfer functions has the same denominator, that is $\det(s[I] - [A])$. The characteristic equation of the system is $\det(s[I] - [A]) = 0$.

The elements of the state-variable transfer function matrix $\left[\frac{\underline{X}}{\underline{U}}(s) \right]_{N \times M}$ are written as follows.

$$\left[\frac{\underline{X}}{\underline{U}}(s) \right]_{ij} = \left[\frac{X_i(s)}{U_j(s)} \right] \quad \begin{cases} "i" \text{ is the row indicator } (i = 1, \dots, N) \\ "j" \text{ is the column indicator } (j = 1, \dots, M) \end{cases} \quad (5)$$

Given the matrix of state-variable transfer functions, Laplace transforms can be used to find the transfer functions associated with the output variables as follows.

$$\begin{aligned} \underline{Z}(s) &= [C]\underline{X}(s) + [D]\underline{U}(s) \\ &= [C] \left[\frac{\underline{X}}{\underline{U}}(s) \right] \underline{U}(s) + [D]\underline{U}(s) \\ &= \left([C] \left[\frac{\underline{X}}{\underline{U}}(s) \right] + [D] \right) \underline{U}(s) \end{aligned} \quad (6)$$

The elements of the output-variable transfer function matrix $\left[\frac{\underline{Z}}{\underline{U}}(s) \right]_{K \times M}$ are written as follows.

$$\left[\frac{\underline{Z}}{\underline{U}}(s) \right]_{ij} = \left[\frac{Z_i(s)}{U_j(s)} \right] = \left[\left([C] \left[\frac{\underline{X}}{\underline{U}}(s) \right] + [D] \right) \right]_{ij} \quad \begin{cases} "i" \text{ is the row indicator } (i = 1, \dots, K) \\ "j" \text{ is the column indicator } (j = 1, \dots, M) \end{cases} \quad (7)$$

Example:

Find the transfer function $\frac{Z(s)}{U(s)}$ for the system of equations

$$\left\{ \begin{array}{l} \dot{x}_1 \\ \dot{x}_2 \end{array} \right\} = \begin{bmatrix} 0 & 1 \\ -e & -b \end{bmatrix} \left\{ \begin{array}{l} x_1 \\ x_2 \end{array} \right\} + \begin{bmatrix} 0 \\ 1 \end{bmatrix} u \quad \text{with the output equation} \quad z = \begin{bmatrix} a & 1 \end{bmatrix} \left\{ \begin{array}{l} x_1 \\ x_2 \end{array} \right\} + [0]u \quad (8)$$

Solution:

Form the matrix equation $(s[I] - [A])X(s) = [B]U(s)$.

$$\begin{bmatrix} s & -1 \\ e & s+b \end{bmatrix} \underline{X}(s) = \begin{bmatrix} 0 \\ 1 \end{bmatrix} U(s) \quad (9)$$

Using Cramer's rule, solve for the state-variable transfer functions

$$\left[\frac{X_1(s)}{U(s)} = \frac{\det \begin{bmatrix} 0 & -1 \\ 1 & s+b \end{bmatrix}}{\det \begin{bmatrix} s & -1 \\ e & s+b \end{bmatrix}} = \frac{1}{s^2 + bs + e} \right] \quad \left[\frac{X_2(s)}{U(s)} = \frac{\det \begin{bmatrix} s & 0 \\ e & 1 \end{bmatrix}}{\det \begin{bmatrix} s & -1 \\ e & s+b \end{bmatrix}} = \frac{s}{s^2 + bs + e} \right] \quad (10)$$

The transfer function to the output variable can then be calculated as follows.

$$\frac{Z(s)}{U(s)} = \left([C] \begin{bmatrix} \tilde{X}(s) \\ \tilde{U}(s) \end{bmatrix} \right) + [D] = \left([a \quad 1] \begin{bmatrix} \left[\begin{array}{c} \frac{X_1(s)}{U} \\ \frac{X_2(s)}{U} \end{array} \right] \\ U \end{bmatrix} \right) + [0] = \frac{a}{s^2 + bs + e} + \frac{s}{s^2 + bs + e} \quad (11)$$

$$\Rightarrow \boxed{\frac{Z(s)}{U(s)} = \frac{s+a}{s^2 + bs + e}}$$

Note the characteristic equation of the system is $\det(s[I] - [A]) = s^2 + bs + e = 0$.

Example:

Find the transfer function $\frac{Z(s)}{U(s)}$ for the system of equations

$$\begin{bmatrix} \dot{x}_1 \\ \dot{x}_2 \\ \dot{x}_3 \end{bmatrix} = \begin{bmatrix} 0 & 0 & 1 \\ -0.6K & 0 & 0 \\ -4 & 1 & -2 \end{bmatrix} \begin{bmatrix} x_1 \\ x_2 \\ x_3 \end{bmatrix} + \begin{bmatrix} 0 \\ 0.6K \\ 0 \end{bmatrix} u \quad \text{with the output equation} \quad z = \begin{bmatrix} 1 & 0 & 0 \end{bmatrix} \begin{bmatrix} x_1 \\ x_2 \\ x_3 \end{bmatrix} \quad (12)$$

Solution:

The output equation defines $z = x_1$, so find the transfer function $\frac{X_1(s)}{U(s)}$. To do this, first form the equation

$$(s[I] - [A]) \tilde{X}(s) = [B]U(s).$$

$$\begin{bmatrix} s & 0 & -1 \\ 0.6K & s & 0 \\ 4 & -1 & s+2 \end{bmatrix} \tilde{X}(s) = \begin{bmatrix} 0 \\ 0.6K \\ 0 \end{bmatrix} U(s) \quad (13)$$

Then, using Cramer's rule, find $\frac{X_1(s)}{U(s)}$

$$\frac{X_1(s)}{U(s)} = \frac{\det \begin{bmatrix} 0 & 0 & -1 \\ 0.6K & s & 0 \\ 0 & -1 & s+2 \end{bmatrix}}{\det \begin{bmatrix} s & 0 & -1 \\ 0.6K & s & 0 \\ 4 & -1 & s+2 \end{bmatrix}} = \frac{0.6K}{s(s^2 + 2s) + (0.6K + 4s)} = \frac{0.6K}{s^3 + 2s^2 + 4s + 0.6K} \quad (14)$$

Note the characteristic equation of the system is $\det(s[I] - [A]) = s^3 + 2s^2 + 4s + 0.6K = 0$.

MATLAB Note:

To convert a state-space model to a transfer function, use the command: `[num, den]=ss2tf(A, B, C, D, i)`. This command generates a set of numerators and denominators from the i^{th} input to all the output variables.

Example:

Using MATLAB, find the transfer function $\frac{X_1(s)}{U(s)}$ for the following system of equations with $K = 1$.

$$\begin{cases} \dot{x}_1 \\ \dot{x}_2 \\ \dot{x}_3 \end{cases} = \begin{bmatrix} 0 & 0 & 1 \\ -0.6K & 0 & 0 \\ -4 & 1 & -2 \end{bmatrix} \begin{cases} x_1 \\ x_2 \\ x_3 \end{cases} + \begin{cases} 0 \\ 0.6K \\ 0 \end{cases} u \quad \text{with the output equation} \quad z = \begin{bmatrix} 1 & 0 & 0 \end{bmatrix} \begin{cases} x_1 \\ x_2 \\ x_3 \end{cases} \quad (15)$$

Solution:

MATLAB Commands and Result:

```
>> A = [0, 0, 1; -0.6, 0, 0; -4, 1, -2];
>> B = [0; 0.6; 0];
>> C = [1, 0, 0];
>> D = 0;
>> [num,den] = ss2tf(A,B,C,D,1);
>> sys = tf(num,den)
sys =
      0.6
-----
s^3 + 2 s^2 + 4 s + 0.6
```

This result is identical to that in Eq. (14) for $K = 1$.

Example:

Using MATLAB, find the transfer functions $\frac{X_i(s)}{F_1(s)}$ ($i = 1, 2, 3, 4$) for the following system of equations associated with the double mass-spring-damper system shown in Fig. 1.

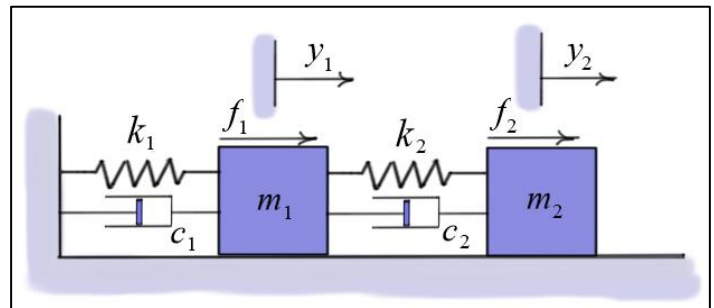

Fig. 1 Double Mass-Spring Damper System

$$\dot{\tilde{x}} = \begin{bmatrix} 0 & 0 & 1 & 0 \\ 0 & 0 & 0 & 1 \\ -(k_1 + k_2)/m_1 & k_2/m_1 & -(c_1 + c_2)/m_1 & c_2/m_1 \\ k_2/m_2 & -k_2/m_2 & c_2/m_2 & -c_2/m_2 \end{bmatrix} \tilde{x} + \begin{bmatrix} 0 & 0 \\ 0 & 0 \\ 1/m_1 & 0 \\ 0 & 1/m_2 \end{bmatrix} u \quad (16)$$

with the output equation

$$\tilde{z} = \begin{bmatrix} 1 & 0 & 0 & 0 \\ 0 & 1 & 0 & 0 \\ 0 & 0 & 1 & 0 \\ 0 & 0 & 0 & 1 \end{bmatrix} \tilde{x} + \begin{bmatrix} 0 & 0 \\ 0 & 0 \\ 0 & 0 \\ 0 & 0 \end{bmatrix} \tilde{u}$$

The state and output variables are defined as: $x_1 \triangleq y_1$ $x_2 \triangleq y_2$ $x_3 \triangleq \dot{y}_1$ $x_4 \triangleq \dot{y}_2$ $u_1 \triangleq f_1$ $u_2 \triangleq f_2$

Use the physical parameters: $m_1 = 0.2$ (slugs) $m_2 = 0.4$ (slugs) $k_1 = k_2 = 3000$ (lb/ft) $c_1 = c_2 = 0$

Solution:

The text box shows the contents of a MATLAB m-file that calculates four transfer functions associated with the double mass-spring damper system of Fig. 1.

```

% This m-file finds the transfer functions associated with the
% double mass-spring-damper system of Fig. 1.

% Masses (slugs)
m1 = 0.2; m2 = 0.4;
mu1 = 1/m1; mu2 = 1/m2;

% Spring constants (lb/ft)
k1 = 3000; k2 = 3000;
k12 = k1 + k2;

% Damping coefficients (lb-s/ft)
c1 = 0.0; c2 = 0.0;
c12 = c1 + c2;

% State-space coefficient matrices
A = [0, 0, 1, 0; 0, 0, 0, 1; -k12*mu1, k2*mu1, -c12*mu1, c2*mu1; ...
     k2*mu2, -k2*mu2, c2*mu2, -c2*mu2];
B = [0, 0; 0, 0; mu1, 0; 0, mu2];
C = [1, 0, 0, 0; 0, 1, 0, 0; 0, 0, 1, 0; 0, 0, 0, 1];
D = [0, 0; 0, 0; 0, 0; 0, 0];

[num,den] = ss2tf(A,B,C,D,1);

sysX1F1 = tf(num(1,:),den);      sysX2F1 = tf(num(2,:),den);
sysX3F1 = tf(num(3,:),den);      sysX4F1 = tf(num(4,:),den);

```

MATLAB Results:

$$\frac{X_1}{F_1} = \frac{Y_1}{F_1} : \quad \text{sysX1F1} = \frac{5 s^2 + 37500}{s^4 + 1.141e-15 s^3 + 3.75e04 s^2 + 3.751e-12 s + 1.125e08} \quad (17)$$

$$\frac{X_2}{F_1} = \frac{Y_2}{F_1} : \quad \text{sysX2F1} = \frac{37500}{s^4 + 1.141e-15 s^3 + 3.75e04 s^2 + 3.751e-12 s + 1.125e08} \quad (18)$$

$$\frac{X_3}{F_1} = \frac{\dot{Y}_1}{F_1} : \quad \text{sysX3F1} = \frac{5 s^3 + 37500 s}{s^4 + 1.141e-15 s^3 + 3.75e04 s^2 + 3.751e-12 s + 1.125e08} \quad (19)$$

$$\frac{X_4}{F_1} = \frac{\dot{Y}_2}{F_1} : \quad \text{sysX4F1} = \frac{37500 s}{s^4 + 1.141e-15 s^3 + 3.75e04 s^2 + 3.751e-12 s + 1.125e08} \quad (20)$$

In previous notes entitled “Transfer Functions”, the first two of these transfer functions were derived to be

$$\frac{X_1(s)}{F_1(s)} = \left(\frac{m_2 s^2 + k_2}{(m_1 s^2 + k_1 + k_2)(m_2 s^2 + k_2) - k_2^2} \right) \quad \frac{X_2(s)}{F_1(s)} = \left(\frac{k_2}{(m_1 s^2 + k_1 + k_2)(m_2 s^2 + k_2) - k_2^2} \right) \quad (21)$$

Substituting in values of the physical parameters into these results and simplifying gives the same results as presented in Eqs. (17) and (18). The results in Eqs. (19) and (20) are found from Eqs. (17) and (18) by simply multiplying by s (taking a derivative in the s -plane).

Note the characteristic equation of the system with $c_1 = c_2 = 0$ can be calculated as follows.

$$\begin{aligned} \det(s[I] - [A]) &= \det \begin{bmatrix} s & 0 & -1 & 0 \\ 0 & s & 0 & -1 \\ (k_1 + k_2)/m_1 & -k_2/m_1 & s & 0 \\ -k_2/m_2 & k_2/m_2 & 0 & s \end{bmatrix} \\ &= s \det \begin{bmatrix} s & 0 & -1 \\ -k_2/m_1 & s & 0 \\ k_2/m_2 & 0 & s \end{bmatrix} - \det \begin{bmatrix} 0 & s & -1 \\ (k_1 + k_2)/m_1 & -k_2/m_1 & 0 \\ -k_2/m_2 & k_2/m_2 & s \end{bmatrix} \\ &= s \left[s(s^2) + s(k_2/m_2) \right] + \left[s(s(k_1 + k_2)/m_1) + \left(\frac{k_2(k_1 + k_2)}{m_1 m_2} - \frac{k_2^2}{m_1 m_2} \right) \right] \\ &= s^4 + \left(\frac{k_2}{m_2} + \frac{(k_1 + k_2)}{m_1} \right) s^2 + \left(\frac{k_1 k_2}{m_1 m_2} \right) \\ &= s^4 + (37500) s^2 + (1.125E8) \end{aligned}$$

This result is the same as that presented by MATLAB in the four transfer functions in Eqs. (17) – (20).

Using the transfer function $\frac{Y_1}{F_1}(s)$ of Eq. (17) with a forcing function $f_1(t) = 200 \sin(100t)$ (lb), MATLAB

can be used to calculate $y_1(t)$ the position response of mass m_1 . The result is shown Fig. 2 below. This response is identical to that provided in previous notes entitled “Introduction to State-Space Models” for the two-input, two-output state-space model of the mass-spring-damper system given above in Eq. (16).

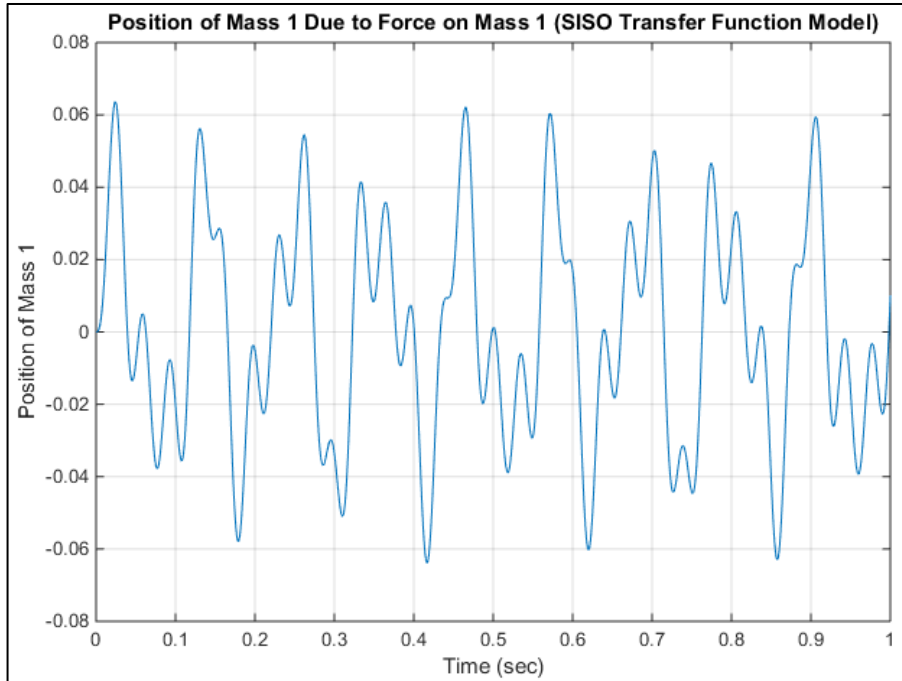

Fig. 2 Position of Mass m_1 due to Force $f_1(t)$ using a Transfer Function

Example: Proportional-Integral Closed-loop Control System

The speed control of a car using proportional-integral control is described by the boxed equations. The desired speed is $r(t)$, the actual speed is $v(t)$, the speed error is $e(t)$, and the driving force is $f(t)$. a) Express the equations in state-space form with output variables $v(t)$ and $e(t)$. b) Using the state-space equations, find

$$\begin{aligned}
 m\dot{v} + cv &= f(t) \\
 e(t) &= r(t) - v(t) \\
 f(t) &= K_1 e(t) + K_2 \int_0^t e(t) dt
 \end{aligned}$$

the transfer functions $\frac{V}{R}(s)$ and $\frac{E}{R}(s)$.

Solution:

a) To find the state-space equations, first rewrite the given equations as follows.

$$\dot{v} = -\left(\frac{c}{m}\right)v - \frac{f}{m} = -\frac{c}{m}v + \frac{1}{m}\left(K_1 e(t) + K_2 \int_0^t e(t) dt\right)$$

Differentiating this result gives

$$\begin{aligned}
 \ddot{v} &= -\left(\frac{c}{m}\right)\dot{v} + \frac{1}{m} \frac{d}{dt} \left(K_1 e(t) + K_2 \int_0^t e(t) dt \right) = -\left(\frac{c}{m}\right)\dot{v} + \frac{1}{m} (K_1 \dot{e}(t) + K_2 e(t)) \\
 &= -\left(\frac{c}{m}\right)\dot{v} + \frac{1}{m} (K_2 (r - v)) + \frac{1}{m} (K_1 (\dot{r} - \dot{v})) \\
 \Rightarrow & \boxed{\ddot{v} = -\frac{1}{m} (c + K_1) \dot{v} - \frac{1}{m} K_2 v + \frac{1}{m} K_2 r + \frac{1}{m} K_1 \dot{r}}
 \end{aligned}$$

Now define the state, input, and output variables as follows. Notice that the input signal $r(t)$ and its derivative are both defined as input signals due to the proportional and integral parts of the compensator. To write the state-space equations, they will be treated as separate (but not independent) input signals.

$$x_1 \triangleq v \quad x_2 \triangleq \dot{v} \quad u_1 \triangleq r \quad u_2 \triangleq \dot{r} \quad z_1 \triangleq v \quad z_2 \triangleq e$$

Using these definitions, the state and output equations can be written as follows.

$$\begin{cases} \dot{x}_1 \\ \dot{x}_2 \end{cases} = \begin{bmatrix} 0 & 1 \\ -\frac{K_2}{m} & -\frac{(c+K_1)}{m} \end{bmatrix} \begin{cases} x_1 \\ x_2 \end{cases} + \begin{bmatrix} 0 & 0 \\ \frac{K_2}{m} & \frac{K_1}{m} \end{bmatrix} \begin{cases} u_1 \\ u_2 \end{cases} \quad \begin{cases} z_1 \\ z_2 \end{cases} = \begin{bmatrix} 1 & 0 \\ -1 & 0 \end{bmatrix} \begin{cases} x_1 \\ x_2 \end{cases} + \begin{bmatrix} 0 & 0 \\ 1 & 0 \end{bmatrix} \begin{cases} u_1 \\ u_2 \end{cases} \quad (22)$$

- b) Using Eqs. (22), the transfer functions $\frac{V}{R}(s)$ and $\frac{E}{R}(s)$ can be found as follows. First, find the matrix $s[I]-[A]$ and its determinant.

$$s[I]-[A] = \begin{bmatrix} s & -1 \\ \frac{K_2}{m} & s + \frac{(c+K_1)}{m} \end{bmatrix} \Rightarrow \det(s[I]-[A]) = s^2 + \left(\frac{c+K_1}{m}\right)s + \frac{K_2}{m}$$

Then, find the four transfer functions that relate the two input signals ($r(t)$, $\dot{r}(t)$) to the two state variables.

$$\frac{X_1}{U_1}(s) = \frac{\det \begin{bmatrix} 0 & -1 \\ \frac{K_2}{m} & s + \frac{(c+K_1)}{m} \end{bmatrix}}{\det(s[I]-[A])} = \frac{\frac{K_2}{m}}{s^2 + \left(\frac{c+K_1}{m}\right)s + \frac{K_2}{m}}$$

$$\frac{X_1}{U_2}(s) = \frac{\det \begin{bmatrix} 0 & -1 \\ \frac{K_1}{m} & s + \frac{(c+K_1)}{m} \end{bmatrix}}{\det(s[I]-[A])} = \frac{\frac{K_1}{m}}{s^2 + \left(\frac{c+K_1}{m}\right)s + \frac{K_2}{m}}$$

$$\frac{X_2}{U_1}(s) = \frac{\det \begin{bmatrix} s & 0 \\ \frac{K_2}{m} & \frac{K_2}{m} \end{bmatrix}}{\det(s[I]-[A])} = \frac{s\left(\frac{K_2}{m}\right)}{s^2 + \left(\frac{c+K_1}{m}\right)s + \frac{K_2}{m}}$$

$$\frac{X_2}{U_2}(s) = \frac{\det \begin{bmatrix} s & 0 \\ \frac{K_2}{m} & \frac{K_1}{m} \end{bmatrix}}{\det(s[I]-[A])} = \frac{s\left(\frac{K_1}{m}\right)}{s^2 + \left(\frac{c+K_1}{m}\right)s + \frac{K_2}{m}}$$

The Laplace transforms of the output signals can now be found as follows. As noted earlier, the input signals are not independent. In fact, $U_2(s) = sU_1(s)$, so

$$\begin{aligned}
\begin{Bmatrix} Z_1(s) \\ Z_2(s) \end{Bmatrix} &= \left[\left([C] \begin{Bmatrix} X \\ \dot{X} \end{Bmatrix} \right) + [D] \right] U = \left[\left([C] \begin{Bmatrix} X_1 & X_1 \\ U_1 & U_2 \\ X_2 & X_2 \\ U_1 & U_2 \end{Bmatrix} \right) + [D] \right] \begin{Bmatrix} U_1 \\ U_2 \end{Bmatrix} \\
&= \left[\left(\begin{bmatrix} 1 & 0 \\ -1 & 0 \end{bmatrix} \begin{bmatrix} \frac{K_2}{m} & \frac{K_1}{m} \\ \frac{s^2 + \left(\frac{c+K_1}{m}\right)s + \frac{K_2}{m}}{s^2 + \left(\frac{c+K_1}{m}\right)s + \frac{K_2}{m}} & \frac{s^2 + \left(\frac{c+K_1}{m}\right)s + \frac{K_2}{m}}{s^2 + \left(\frac{c+K_1}{m}\right)s + \frac{K_2}{m}} \\ s \left(\frac{K_2}{m}\right) & s \left(\frac{K_1}{m}\right) \\ \frac{s^2 + \left(\frac{c+K_1}{m}\right)s + \frac{K_2}{m}}{s^2 + \left(\frac{c+K_1}{m}\right)s + \frac{K_2}{m}} & \frac{s^2 + \left(\frac{c+K_1}{m}\right)s + \frac{K_2}{m}}{s^2 + \left(\frac{c+K_1}{m}\right)s + \frac{K_2}{m}} \end{bmatrix} + \begin{bmatrix} 0 & 0 \\ 1 & 0 \end{bmatrix} \right) \begin{Bmatrix} U_1(s) \\ sU_1(s) \end{Bmatrix} \right] \\
\Rightarrow \begin{Bmatrix} Z_1(s) \\ Z_2(s) \end{Bmatrix} &= \begin{bmatrix} \frac{K_2}{m} & \frac{K_1}{m} \\ \frac{s^2 + \left(\frac{c+K_1}{m}\right)s + \frac{K_2}{m}}{s^2 + \left(\frac{c+K_1}{m}\right)s + \frac{K_2}{m}} & \frac{s^2 + \left(\frac{c+K_1}{m}\right)s + \frac{K_2}{m}}{s^2 + \left(\frac{c+K_1}{m}\right)s + \frac{K_2}{m}} \\ \left(s + \left(\frac{c+K_1}{m}\right) \right) s & -\frac{K_1}{m} \\ \frac{s^2 + \left(\frac{c+K_1}{m}\right)s + \frac{K_2}{m}}{s^2 + \left(\frac{c+K_1}{m}\right)s + \frac{K_2}{m}} & \frac{s^2 + \left(\frac{c+K_1}{m}\right)s + \frac{K_2}{m}}{s^2 + \left(\frac{c+K_1}{m}\right)s + \frac{K_2}{m}} \end{bmatrix} \begin{Bmatrix} U_1(s) \\ sU_1(s) \end{Bmatrix}
\end{aligned}$$

Performing the matrix multiplication on the right side of the above equation and combining terms, the two transfer functions are found to be

$$\boxed{\frac{Z_1(s)}{U_1(s)} = \frac{V}{R}(s) = \frac{\frac{1}{m}(K_1s + K_2)}{s^2 + \left(\frac{c+K_1}{m}\right)s + \frac{K_2}{m}}} \quad \boxed{\frac{Z_2(s)}{U_1(s)} = \frac{E}{R}(s) = \frac{\left(s + \left(\frac{c}{m}\right)\right)s}{s^2 + \left(\frac{c+K_1}{m}\right)s + \frac{K_2}{m}}} \quad (23)$$

Note: A similar process can be followed with proportional-derivative and proportional-integral-derivative compensators.

State-Space Equations, the Characteristic Equation, and Stability

As noted above, the characteristic equation of the system whose state-space equations are as written in Eq. (1) can be written as

$$\boxed{\det(s[I] - [A]) = 0} \quad (24)$$

Calculating the determinant as defined in Eq. (24) results in an N^{th} order polynomial in s . The roots of that polynomial are the **eigenvalues** of the coefficient matrix $[A]$ and the **poles** of the system. As usual, for the system to be **stable**, the poles must lie in the **left half** of the s -plane. If the poles lie on the imaginary axis, the system is considered to be marginally stable.

Converting Transfer Functions to State-Space Equations

The process of converting a transfer function to set of state-space equations is referred to by some as “decomposition”. There are many methods available to perform the decomposition. The most commonly used method is called direct decomposition. Direct decomposition results in state-space equations that are in controllable canonical form. For more information on controllable canonical form see Ogata, *Modern Control Engineering*, 5th Ed., 2010

Direct Decomposition

Consider the transfer function of an n^{th} order dynamic system.

$$\boxed{\frac{Z}{U}(s) = \frac{b_m s^m + b_{m-1} s^{m-1} + \dots + b_1 s + b_0}{s^n + a_{n-1} s^{n-1} + \dots + a_1 s + a_0}} \quad (m < n) \quad (25)$$

To convert this transfer function to a set of state-space equations using direct decomposition, first set the numerator of the transfer function to one and define the Laplace transform of the first state variable $x_1(t)$ as follows.

$$\boxed{X_1(s) = \left[\frac{1}{s^n + a_{n-1} s^{n-1} + \dots + a_1 s + a_0} \right] U(s)} \Rightarrow \boxed{(s^n + a_{n-1} s^{n-1} + \dots + a_1 s + a_0) X_1(s) = U(s)} \quad (26)$$

Then, $Z(s)$ the Laplace transform of the output is

$$\boxed{Z(s) = (b_m s^m + b_{m-1} s^{m-1} + \dots + b_1 s + b_0) X_1(s)} \quad (27)$$

Eq. (26) can be written as an n^{th} order differential equation. Applying inverse Laplace transforms gives

$$\boxed{\frac{d^n x_1}{dt^n} + a_{n-1} \frac{d^{n-1} x_1}{dt^{n-1}} + \dots + a_1 \frac{dx_1}{dt} + a_0 x_1 = u(t)} \quad (28)$$

From Eq. (28) define the rest of the state variables as follows.

$$\boxed{x_2 \triangleq \dot{x}_1} \quad \boxed{x_3 \triangleq \dot{x}_2} \quad \boxed{x_4 \triangleq \dot{x}_3} \quad \dots \quad \boxed{x_n \triangleq \dot{x}_{n-1}} \quad (29)$$

From these definitions it is clear that

$$\boxed{x_2 = \frac{dx_1}{dt}} \quad \boxed{x_3 = \frac{d^2x_1}{dt^2}} \quad \boxed{x_4 = \frac{d^3x_1}{dt^3}} \quad \cdots \quad \boxed{x_{n-1} = \frac{d^{n-2}x_1}{dt^{n-2}}} \quad \boxed{x_n = \frac{d^{n-1}x_1}{dt^{n-1}}} \quad (30)$$

Substituting these results into the differential equation (28) and solving for \dot{x}_n gives

$$\boxed{\frac{d^n x_1}{dt^n} \triangleq \dot{x}_n = -a_0 x_1 - a_1 x_2 - a_2 x_3 - \cdots - a_{n-1} x_n + u(t)} \quad (31)$$

Eqs. (29) and (31) can now be written as a single matrix as follows.

$$\boxed{\dot{\tilde{x}} = [A]\tilde{x} + [B]u} \quad (32)$$

Or,

$$\left\{ \begin{array}{c} \dot{x}_1 \\ \dot{x}_2 \\ \cdot \\ \cdot \\ \dot{x}_{n-1} \\ \dot{x}_n \end{array} \right\} = \underbrace{\left[\begin{array}{cccccc} 0 & 1 & 0 & \cdots & 0 \\ 0 & 0 & 1 & \cdots & 0 \\ \cdot & \cdot & \cdot & \cdots & \cdot \\ \cdot & \cdot & \cdot & \cdots & \cdot \\ \cdot & \cdot & \cdot & \cdots & \cdot \\ 0 & 0 & 0 & \cdots & 1 \\ -a_0 & -a_1 & -a_2 & \cdots & -a_{n-1} \end{array} \right]}_{[A]} \underbrace{\left\{ \begin{array}{c} x_1 \\ x_2 \\ \cdot \\ \cdot \\ x_{n-1} \\ x_n \end{array} \right\}}_{\{x\}} + \underbrace{\left\{ \begin{array}{c} 0 \\ 0 \\ \cdot \\ \cdot \\ 0 \\ 1 \end{array} \right\}}_{[B]} u \quad (33)$$

Following a similar procedure, the output equation can be written in terms of the state variables as follows.

$$\boxed{z(t) = b_0 x_1 + b_1 x_2 + \cdots + b_{m-1} x_m + b_m x_{m+1}} \quad (34)$$

Example:

Use direct decomposition to express the following transfer function in state-space form.

$$\boxed{\frac{Z(s)}{U(s)} = \frac{s+a}{s^2+bs+e}} \quad (35)$$

Solution:

The first step is to define the Laplace transform of the first state variable $X_1(s)$ assuming the numerator of the transfer function is one. That is,

$$(s^2 + bs + e)X_1(s) = U(s)$$

This equation can easily be written in differential equation form as

$$\ddot{x}_1 + b\dot{x}_1 + ex_1 = u(t) \quad (36)$$

Now define the state variables and write to Eq. (36) in state-space form.

$$\text{State variables: } x_1 \triangleq x_1 \quad x_2 \triangleq \dot{x}_1 \quad (37)$$

$$\text{State-space form of Eq. (36): } \boxed{\begin{Bmatrix} \dot{x}_1 \\ \dot{x}_2 \end{Bmatrix} = \begin{bmatrix} 0 & 1 \\ -e & -b \end{bmatrix} \begin{Bmatrix} x_1 \\ x_2 \end{Bmatrix} + \begin{Bmatrix} 0 \\ 1 \end{Bmatrix} u}$$
(38)

Finally, the output equation is written as

$$Z(s) = (s + a)X_1(s)$$

or, in the time-domain,

$$\boxed{z = [a \quad 1] \begin{Bmatrix} x_1 \\ x_2 \end{Bmatrix} + [0]u}$$
(39)

MATLAB Note:

MATLAB defines the “derivatives” to be the lower numbered state variables. For the above system, MATLAB would present the equations as follows.

$$\text{State variables: } y_1 \triangleq \dot{x}_1 \quad y_2 \triangleq x_1$$

$$\text{State-space equations: } \boxed{\begin{Bmatrix} \dot{y}_1 \\ \dot{y}_2 \end{Bmatrix} = \begin{bmatrix} -b & -e \\ 1 & 0 \end{bmatrix} \begin{Bmatrix} y_1 \\ y_2 \end{Bmatrix} + \begin{Bmatrix} 1 \\ 0 \end{Bmatrix} u}$$

$$\text{Output equation: } \boxed{z = [1 \quad a] \begin{Bmatrix} y_1 \\ y_2 \end{Bmatrix} + [0]u}$$

To find the state-space coefficient matrices for a given transfer function, use the command “[A, B, C, D] = tf2ss (num, den)”.

Example:

Use the direct decomposition method to express the following transfer function in state-space form.

$$\boxed{\frac{Z(s)}{U(s)} = \frac{0.6K}{s^3 + 2s^2 + 4s + 0.6K}}$$
(40)

Solution:

The first step is to define the state variable $X_1(s)$ assuming the numerator of the transfer function is one and write

$$(s^3 + 2s^2 + 4s + 0.6K)X_1(s) = U(s)$$

This equation can easily be written in differential equation form as

$$\ddot{x}_1 + 2\dot{x}_1 + 4x_1 + 0.6Kx_1 = u(t)$$
(41)

Now define the state variables and write Eq. (41) in state-space form.

$$\text{State variables: } x_1 \triangleq x_1 \quad x_2 \triangleq \dot{x}_1 \quad x_3 \triangleq \ddot{x}_1$$

State-space form of Eq. (41):

$$\begin{cases} \dot{x}_1 \\ \dot{x}_2 \\ \dot{x}_3 \end{cases} = \begin{bmatrix} 0 & 1 & 0 \\ 0 & 0 & 1 \\ -0.6K & -4 & -2 \end{bmatrix} \begin{cases} x_1 \\ x_2 \\ x_3 \end{cases} + \begin{cases} 0 \\ 0 \\ 1 \end{cases} u \quad (42)$$

Finally, the output equation is written as

$$Z(s) = 0.6K X_1(s)$$

or, in the time-domain,

$$z = [0.6K] x_1 + [0] u \quad (43)$$

Eqs. (42) and (43) are different than Eqs. (15) presented above, but in fact, they represent the same system. This is easily verified by finding the third-order differential equation associated with the two sets of equations. Expanding Eqs. (15) gives

$$\dot{x}_2 = -0.6K x_1 + 0.6K u \quad \text{and} \quad \dot{x}_3 \triangleq \ddot{x}_1 = -4x_1 + x_2 - 2\dot{x}_1$$

Differentiating the second equation, substituting for \dot{x}_2 from the first equation and rearranging terms gives

$$\ddot{x}_1 + 2\dot{x}_1 + 4x_1 + 0.6K x_1 = 0.6K u(t) \quad x_1 \text{ is the output variable} \quad (44)$$

Expanding Eq. (42) gives

$$\dot{x}_3 \triangleq \ddot{x}_2 \triangleq \ddot{x}_1 = -2\dot{x}_1 - 4x_1 - 0.6K x_1 + u(t) \quad \text{and} \quad z = 0.6K x_1$$

Rearranging the first equation gives

$$\ddot{x}_1 + 2\dot{x}_1 + 4x_1 + 0.6K x_1 = u(t) \quad z = 0.6K x_1 \text{ is the output variable} \quad (45)$$

Because the system is linear, state-variable x_1 from Eq. (44) will be $0.6K$ times the state-variable x_1 from Eq. (45). So, the output variable of Eq. (44) is the same as the output variable from Eq. (45).

Example:

Use the direct decomposition method to express the following transfer function from the double mass-spring-damper system in state-space form.

$$\frac{Y_1(s)}{F_1(s)} = \left(\frac{m_2 s^2 + k_2}{(m_1 s^2 + k_1 + k_2)(m_2 s^2 + k_2) - k_2^2} \right) \quad (46)$$

The first step is to define the state variable $X_1(s)$ assuming the numerator of the transfer function is one and write

$$\begin{aligned} ((m_1 s^2 + k_1 + k_2)(m_2 s^2 + k_2) - k_2^2) X_1(s) &= F_1(s) \\ \Rightarrow (m_1 m_2 s^4 + (m_1 k_2 + m_2(k_1 + k_2)) s^2 + k_1 k_2) X_1(s) &= F_1(s) \end{aligned}$$

This equation can easily be written in differential equation form as

$$(m_1 m_2) \ddot{x}_1 + (m_1 k_2 + m_2 (k_1 + k_2)) \dot{x}_1 + (k_1 k_2) x_1 = f_1(t) \quad (47)$$

Now define the state variables and write Eq. (47) in state space form

$$\text{State variables: } x_1 \triangleq x_1 \quad x_2 \triangleq \dot{x}_1 \quad x_3 \triangleq \ddot{x}_1 \quad x_4 \triangleq \dddot{x}_1$$

$$\text{State-space form: } \begin{cases} \dot{x}_1 \\ \dot{x}_2 \\ \dot{x}_3 \\ \dot{x}_4 \end{cases} = \begin{bmatrix} 0 & 1 & 0 & 0 \\ 0 & 0 & 1 & 0 \\ 0 & 0 & 0 & 1 \\ -\frac{k_1 k_2}{m_1 m_2} & 0 & -\frac{(m_1 k_2 + m_2 (k_1 + k_2))}{m_1 m_2} & 0 \end{bmatrix} \begin{cases} x_1 \\ x_2 \\ x_3 \\ x_4 \end{cases} + \begin{bmatrix} 0 \\ 0 \\ 0 \\ \frac{1}{m_1 m_2} \end{bmatrix} f_1(t) \quad (48)$$

Finally, the output equation is

$$Y_1(s) = (m_2 s^2 + k_2) X_1(s)$$

Or, in the time domain

$$y_1(t) = m_2 \ddot{x}_1 + k_2 x_1 = m_2 x_3 + k_2 x_1$$

$$\Rightarrow y_1 = \begin{bmatrix} k_2 & 0 & m_2 & 0 \end{bmatrix} \begin{cases} x_1 \\ x_2 \\ x_3 \\ x_4 \end{cases} + \begin{bmatrix} 0 \end{bmatrix} f_1 \quad (49)$$

The single-input single-output state-space model of Eqs. (48) and (49) is encoded in the Simulink model shown below in Fig. 3. The summing block on the left is the right side of the fourth equation of Eqs. (48) which represents \dot{x}_4 . That signal is integrated four times to find the state variable $x_1(t)$. Variable $MK \triangleq \frac{(m_1 k_2 + m_2 (k_1 + k_2))}{m_1 m_2}$, variable $KK \triangleq \frac{k_1 k_2}{m_1 m_2}$, and the variables m_1 , m_2 , k_1 , and k_2 represent the masses and spring stiffnesses (as in previous models). The output equation that calculates $y_1(t)$ is highlighted in the red oval.

Given the input force of $f_1(t) = 200 \sin(100t)$ (lb), this Simulink model produces the result shown in Fig. 4 for the position of mass m_1 . These results are identical to the results presented earlier for the two-input, two-output state-space model and the transfer function model of the system. All three models represent the dynamics of the same system.

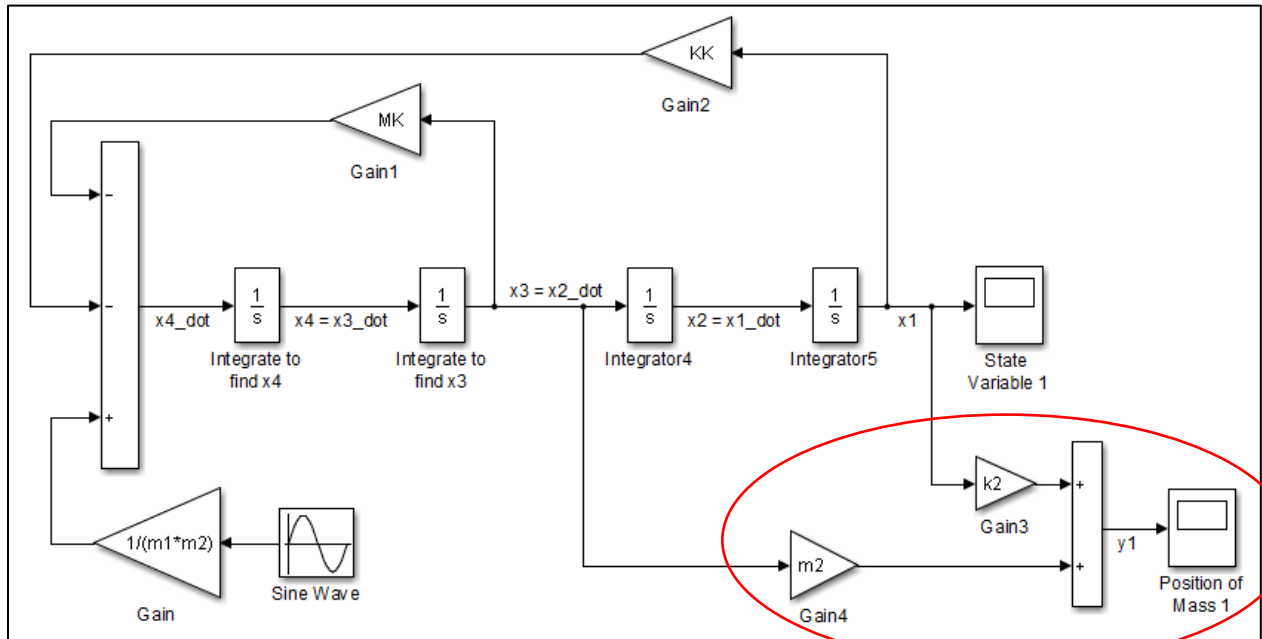

Fig. 3 SISO State-Space Model of a Mass-Spring-Damper System

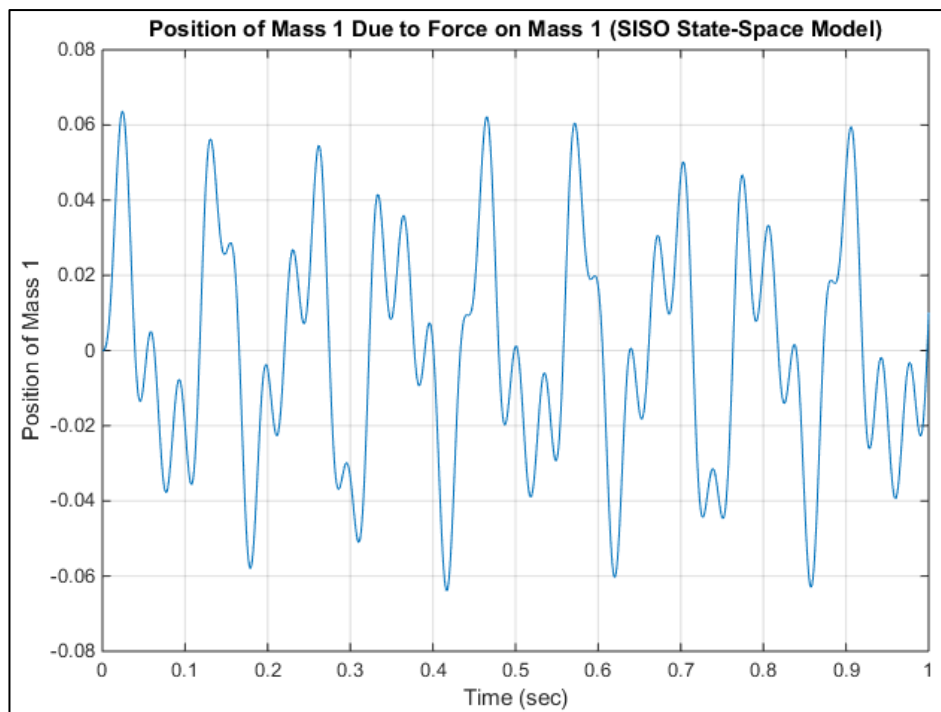

Fig. 4 Position of Mass m_1 due to Force $f_1(t)$ using a SISO State-Space Model