

Introductory Control Systems

Control Systems Terminology

Block diagrams are used to describe *how* systems function. The diagrams may describe the *overall operation* of a system, or they may be *very detailed* describing even the smallest processes within the system. They are used quite extensively in control system design, especially in single-input/single-output systems.

In a standard block diagram, *lines* represent *signals*, and *blocks* represent *processes* (also called *plants*). The representation is just the reverse in signal flow graphs. These notes focus on the use of block diagrams to describe the operation of continuous systems.

Systems can generally be defined as either being *open-* or *closed-loop*. In *open-loop* systems, the *input* to the plant is *independent* of its *output*. For example, if the plant is a body, the *input* may be a *force*, and the *output* an *acceleration*. Conversely, in *closed-loop* systems, the *input* to the plant is *continually modified* as a *function* of the *output* of the plant. For example, if the *plant* is a *car with speed control*, the *input* may be a *desired speed*, and the *output* the *actual* (or *measured*) *speed*. The *difference* between the desired and actual speed (speed error), then becomes an input to the car's speed control system.

The next two figures represent simple open-loop and closed-loop block diagrams. The signals are shown as *arrows* to indicate the *direction* of flow. By convention, the *input signals* are shown on the *left*, and the *output signals* are shown on the *right*. Using this convention as a reference, signals that flow from *left to right* are called *forward-path* signals, and those that flow from *right to left* are called *feedback* signals. In a closed-loop system, the output signal is fed back to create an *error signal* using a *summing* (or differencing) *block*. The summing block is indicated by a circle in the diagram.

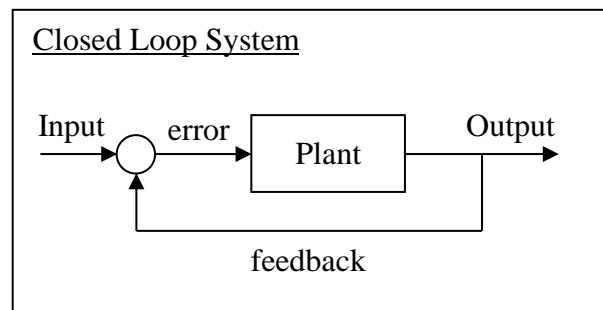
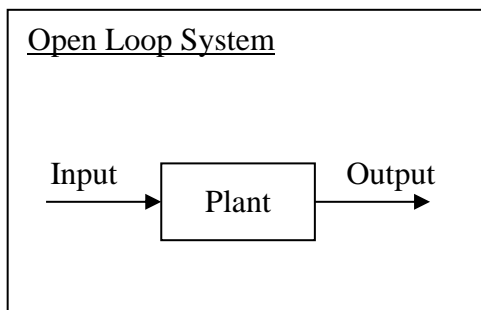

The notes that follow concentrate mainly on the use of a *feedback* signal to control the action of plants. However, plants can also be controlled using a *feed-forward* signal as indicated in the following diagram. In this case, the input signal is sent to the plant and through a parallel path to a controller that sends input to the plant as well.

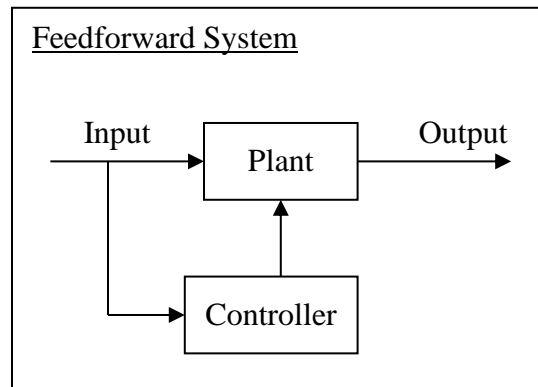

If the behaviour of a plant is *linear*, that is, if it can be described using a *linear algebraic* or a *linear differential* equation, then the plant can be described using a *transfer function*, indicated by $G(s)$ in the diagram below. The purpose of a transfer function is to provide an *accurate quantitative representation* of the output of the plant given its input. Transfer functions associated with linear differential equations can be found using *Laplace transforms*.

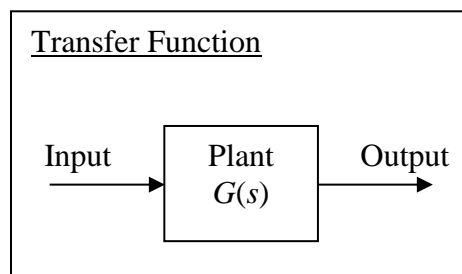

Actuators are *components* of the system that can be used to *drive* (or affect) the plant. The diagram below shows two examples. In the first example, a *motor* (the actuator) is used to *drive* a *shaft* (the plant). The input to the motor may be a *voltage*, and the output of the shaft may be its *rotational speed*. The second example shows a *heater* (the actuator) used to heat a *fluid* (the plant). The input to the heater may be a voltage, and the output of the fluid may be its temperature.

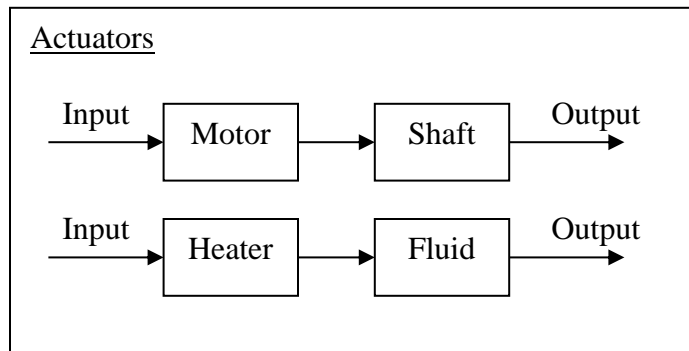

Sensors are components in the system used to *measure* important characteristics. The diagram below shows two examples. In the first example, a *motor* (the actuator) is used to drive a *shaft* (the plant), and a *tachometer* is used to *measure* the output speed of the shaft. In the second example, a *heater* (the actuator) is used to heat a *fluid* (the plant), and a *thermocouple* is used to *measure* the temperature.

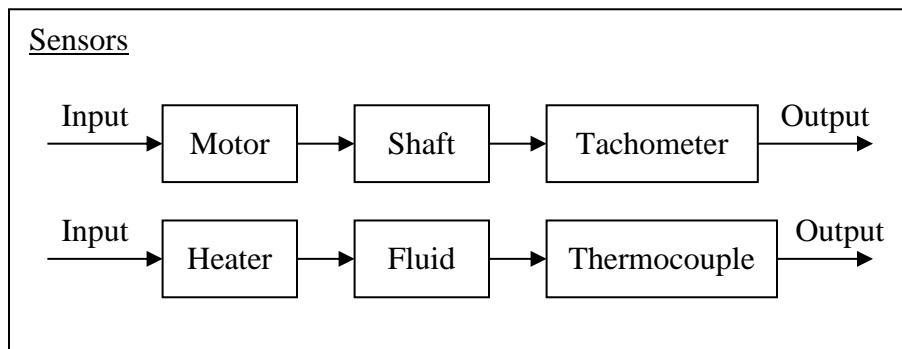

The above concepts can be combined into a single block diagram. The diagram below shows an *ideal single, closed-loop system* with a *single input* signal, a *single output* signal, a *control device*, an *actuator*, a *plant*, and a *sensor*. As shown, the input to the system may be a *desired shaft speed*, and the output of the system may be the *measured speed*. The control device may be an electronic circuit, for example.

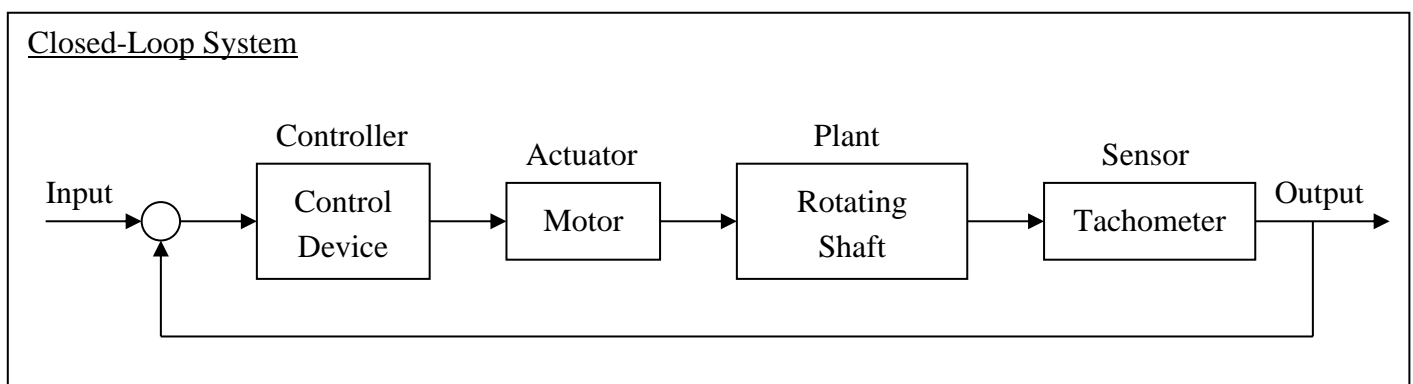

The diagram below shows the same system with *realistic* input signals associated with *external disturbances* and *sensor noise*. By *convention*, external disturbances are assumed to *directly* affect the plant. Noise is usually associated with sensors.

